

CAVITY NO.

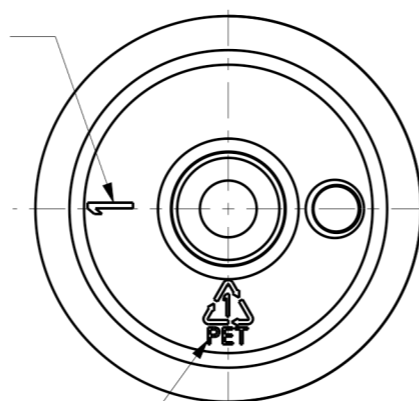

RECYCLE MARK

NECK FINISH
THREAD SP 24
2 TURNS
PITCH: 3,18 [mm]

Material	PET	Weight	12 ± 0.8 [g]	Overflow capacity	60 ± 3 [ml]
Designed	04.03.20	Project name Bottle 50 ml			
Checked	04.03.20				
Scale	Format	Project number F6100			
3:2	A3				